

RECOMMENDED P.C.B. LAYOUT
TOLERANCE UNSPECIFIED ±0.05mm

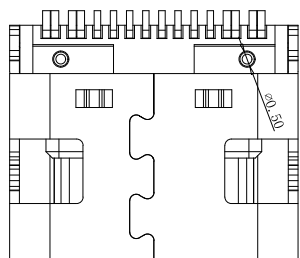

A1	GND	B12	GND
A4	VBUS	B9	VBUS
A5	CC1	B8	SBU2
A6	DP1	B7	DN2
A7	DN1	B6	DP2
A8	SBU1	B5	CC2
A9	VBUS	B4	VBUS
A12	GND	B1	GND
PIN	SIGNAL NAME	PIN	SIGNAL NAME

备注:

1. 材质:
 - 1.1 胶芯: LCP+30%G.F UL94V-0
 - 1.2 端子: 高导电C7025/C2680; 镍底30U" MIN, 接触区域镀金 (AU 1u") 焊接区镀金G/F
 - 1.3 外壳: SUS201/SUS304, T=0.30mm; 表面镀镍30U" MIN
 - 1.4 中夹片: SUS301;
2. 主要特性:
 - 2.1 额定电流: 3A/5A
 - 2.2 接触阻抗: 40mΩ MAX (初始值) 50mΩ MAX (测试后)
 - 2.3 绝缘阻抗: 100MΩ MIN
 - 2.4 耐压测试: 100V AC R.M.S.
 - 2.6 整体插入力: 5-20N 整体插入力: 5-20N (耐久后) 整体拔出力: 8-20N 整体拔出力: 6-20N (耐久后)
 - 2.7 耐久: 10000次
 - 2.8 耐高温: SMT回流焊 (峰值260° ±5°), 塑胶不能有起泡, 融胶等不良, 变色, 翘曲变形在公差范围以内;
 - 2.9 产品须做焊锡测试, 粘锡面积达到95%以上;
 - 3.0 盐雾测试: 24H MIN
 - 3.1 工作温度: -30℃~+85℃

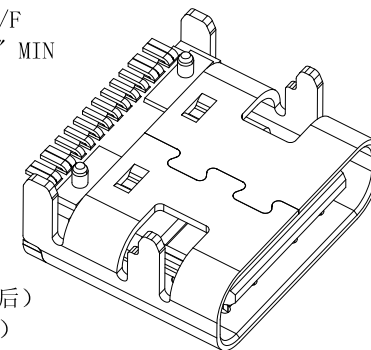

料号编码:

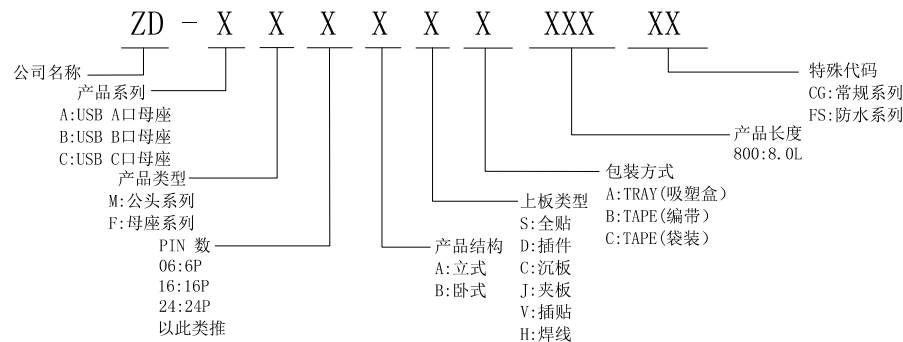

振端精密科技(深圳)有限公司
Zhenduan Precision Technology (Shenzhen) Co., Ltd

TITLE: USB C TYPE CONNECTOR
16P四脚板上四脚插板端子SMT
L=7.35mm
业务图

DRAW NO: ZD-CF16BVB735CG01
TEL: 0755-29888153
Http://www.szzdjm.com

THIRD ANGLE PROJECTION	UNIT:	SCALE:	SIZE:	SHEET:
	mm	1:1	A4	1/2

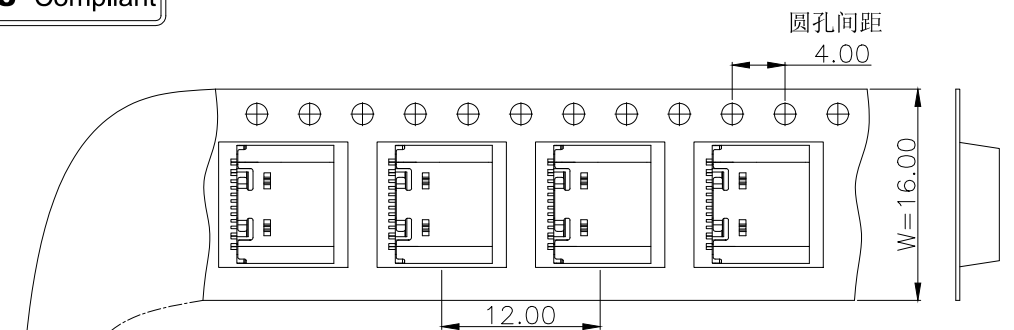

包装示意图:

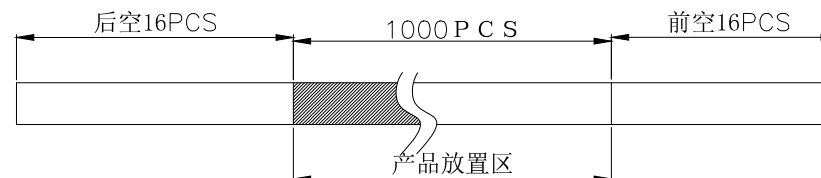

客户拉出方向

自粘上带(上带剥离力0.2-1.2N)

前端

产品内标签
产品标签格式(所有包装格式一致,只需更改数量即可)

产品外标签

备注:

1. 把上下载带送入载带机进行调整,然后将产品按照指定的方式摆入下载带中,开动卷带机进行卷装(每卷包1000PCS),
2. 在卷装OK的每卷盘面的指定位置上贴上物料标签装入纸箱内;每箱装15盘
3. 纸箱用封箱带将其封好,胶带要求工字型,不可遮住标签;
4. 如果客户对包装标签另有要求,请按客户要求作业;有未满足之零数箱需用缓冲材料填充;
5. 上载带剥离力0.2-1.2N.;

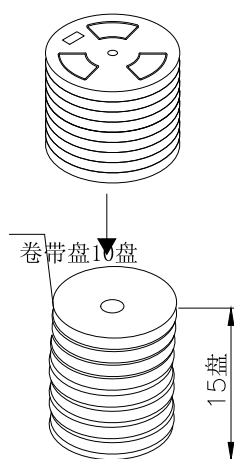

将15盘产品放入纸箱内

纸箱规格:
34.0X34.0X32CM

振端科技
ZHENDUAN 振端精密科技(深圳)有限公司
Zhenduan Precision Technology (Shenzhen) Co., Ltd

TITLE: USB C TYPE CONNECTOR
16P四脚板上四脚插板端子SMT
L=7.35mm 包装图
业务图

DRAW NO: ZD-CF16BVB735CG01

TEL: 0755-29888153

Http://www.szzdjm.com

THIRD ANGLE PROJECTION

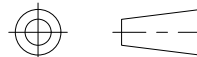

UNIT:

mm

SCALE:

1:1

SIZE:

A4

SHEET:

2/2